



CAUTION

Precautions when sending your Wii U console or Wii U GamePad for repair

Please read the following precautions when sending your console or GamePad for repair in order to protect them from damage during transit:

Packaging the Wii U console

- Wrap the console in cling film, a soft cloth or similar material.

Packaging the Wii U GamePad

- Use the original packaging from when the console was purchased to protect the screen from being scratched or otherwise damaged.

Note: If you do not have the original packaging, please wrap the GamePad in a soft cloth or similar material.

Do not use cling film for the Wii U GamePad, as wrapping it too tightly may damage the control sticks or buttons.

Precautions for boxing items

- Fill any excess space in the box with a cushioning material (such as bubble wrap or paper) to minimise movement inside the box during transit.
- When packaging the Wii U GamePad, do not place anything heavy on top of the screen, such as the Wii U console or its AC adapter.

Before returning the Product for assessment,
visit our website www.nintendo.com.au
for product support and service information,
or contact Nintendo Customer Service using the details below:

Nintendo Customer Service

Australia: (03) 9730 9822

New Zealand: 0800 743 056

Hours of operation: 9:00am to 5:00pm Monday to Friday (AEST/AEDT)

Call charges vary. Check with your telecommunications provider.

Email: warrantyadmin@na.nintendo.com.au



Wii U Operations Manual

NINTENDO AUSTRALIA PTY. LTD.
Scoresby Industrial Park, 804 Stud Road, Scoresby Victoria 3179 Australia
www.nintendo.com.au
support.nintendo.com



MAB-WUP-S-AUS-C4



This seal is your assurance that Nintendo has reviewed this product and that it has met our standards for excellence in workmanship, reliability and entertainment value. Always look for this seal when buying games and accessories to ensure complete compatibility with your Nintendo Product.



Thank you for selecting the Wii U™ console.

IMPORTANT: Please read this Operations Manual and accompanying Important Information booklet before use, paying careful attention to the health and safety information in both documents. Please also make sure you read the health and safety information in the Health and Safety Information application on the Wii U Menu once the console has been set up. If this product is to be used by children, the documentation should be read and explained to them by an adult. Store all documentation in a safe place.

IMPORTANT: Nintendo may automatically update your Wii U console or Wii U software to ensure the security and proper functioning of your Wii U console, to improve the service or to protect the intellectual property of Nintendo or third parties.

This product contains technological protection measures. Your Wii U console is not designed for use with any existing or future unauthorised device or software that enables technical modification of the Wii U console or software.

Any such unauthorised use may render your Wii U console permanently unplayable and result in removal of content.

Any software included in the Wii U console as well as any updates of such software (together "the Software") are licensed by Nintendo only for personal and non-commercial use on the Wii U console. The Software must not be used for any other purpose. In particular, without Nintendo's written consent, you must neither lease or rent the Software nor sublicense, publish, copy, modify, adapt, translate, reverse engineer, decompile or disassemble any portion of the Software other than as expressly permitted by applicable law.

For use with the European/Australian version of Wii U and Wii software only.

Parental Controls

You can restrict the ways in which children use the Wii U console, for example by restricting the use of software, purchases in Nintendo eShop, viewing of websites and other features.

During initial setup of the console, you will be asked to configure Parental Controls. Follow the on-screen instructions to set specific restrictions. To view or change Parental Controls settings after the initial setup has been completed, select Parental Controls from the Wii U Menu.

The Parental Controls settings are protected by a PIN code that you are prompted to choose the first time you configure Parental Controls.

For more information, please see the Quick Start Guide.

Nintendo may automatically update your Wii U console from time to time, so the information provided in this manual may become outdated. Nintendo therefore recommends checking for the latest version of this manual on your local Nintendo website in the support section for this product.

Trademarks are property of their respective owners.

Wii U is a trademark of Nintendo.

© 2012 Nintendo Co., Ltd.

Contents

Wii U Documentation	4	How-To	22
Types of Documentation	4	Using Wii Software	22
Using Electronic Manuals	4	Preparation	22
Important Health and Safety Information (Please read)	5	Transferring Software and Data from Wii to Wii U	23
Getting Started	7	Transferable Data	23
Component Names and Functions	7	Preparing for the Transfer	24
Wii U Console	7	Transfer Procedure	24
Wii U GamePad	8	Transferring Software and Data between Wii U Consoles	27
Charging the Wii U GamePad	11	Transferable Data	28
How to Charge	11	Preparing for the Transfer	29
Reading the Battery LED	12	Transfer Procedure	30
Turning the Power On/Off	13	Calibrating Controllers	32
Turning the Power On	13	Calibrating the Touch Screen	32
Turning the Wii U GamePad Screen Off	14	Calibrating the Control Sticks	32
Turning the Power Off	14	Calibrating the Motion Controls	32
Pairing Controllers	16	Replacing and Removing Batteries	33
Pairing Wii Remotes and Other Controllers	16	Wii U GamePad Battery	33
Pairing a Wii U GamePad	16	Handling Used Batteries	35
Positioning the Sensor Bar	17	Wii U Console Battery	36
How to Position the Sensor Bar	17	Handling Used Lithium Coin Cell Batteries	36
Play Environment	18	Troubleshooting	37
Settings	19	Power and Temperature of Devices	37
System Settings	19	GamePad Charging and Batteries	39
Configuring Settings	19	TV Display and Audio	40
User Settings	20	Wii U GamePad Display and Touch Screen Response	41
Nintendo Network ID	20	Controller Operations	42
Changing User Settings	21	Requesting Repairs	43
Adding/Switching Users	21		

Wii U Documentation

Types of Documentation

Manuels packaged with the console

- Quick Start Guide**
Provides information on getting ready to use the Wii U™ console for the first time.
- Wii U Operations Manual (this manual)**
Provides information on topics such as part names, recharging, System Settings options and troubleshooting.
- Important Information booklet**
Contains important information regarding health and safety, warranties, support information, disposal of the product and so on.

Manuels built in to the Wii U console

- Wii U Electronic Manual**
Includes detailed explanations on how to use Wii U features and pre-installed software.
- Wii Menu Electronic Manual**
Includes detailed explanations on how to use Wii Menu features and pre-installed software.

Using Electronic Manuals

Press the HOME Button on the Wii U GamePad while the Wii U Menu is displayed to open the HOME Menu, then touch . The Wii U Electronic Manual will appear.

- If you press the HOME Button while using a Wii U software title, touching will display the electronic manual for that software instead.
- To close the manual, touch in the bottom left of the screen. The console will return to the screen it was displaying before you pressed the HOME Button.



Touch or slide on the screen using the Wii U GamePad stylus (p. 9) to view the contents of the manual.

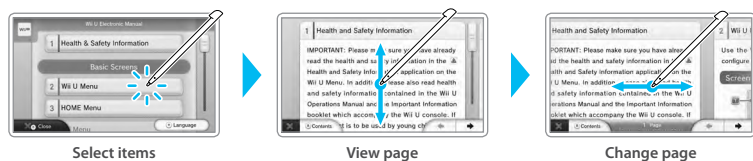

- Note that the screens and illustrations shown were taken during development and may differ from those found in the final product.
- To change the language of the electronic manual, select the option shown in the bottom-right corner of the screen.

Important Health and Safety Information (Please read)

To prevent damage to your health, and accidents caused by fire or electric shock etc., make sure you read the contents of the Health and Safety Information application on the Wii U Menu and the Important Information booklet packaged with the console, and use the console as instructed.



Use of this product by children

Read the contents of the Health and Safety Information application on the Wii U Menu and the Important Information booklet as well as any instruction manuals before use, and accompany your child or children during their use of the console.

Perform regular checks

Perform regular checks of the console and its parts, for example making sure that the AC adapter cord or plug is not damaged, that dust has not gathered between the AC adapter plug and electrical outlet, that dust has not collected in the air intake and air vents of the console, and so on.

If the system doesn't operate properly

Review the Troubleshooting chapter of the manual (p. 37).

If a problem occurs

(If you notice any damage to the console, smoke or unusual sounds or smells etc.)

1 Turn off

Hold down the POWER Button for at least one second.

- You should touch only the POWER Button. Do not touch any other part of the console.

2 Unplug

Unplug the AC adapter from the electrical outlet.

- Disconnect any connected peripherals as well.

3 Contact

Contact Nintendo Customer Service (see Important Information booklet).

- Do not attempt to repair the console yourself. To do so could cause injury.

AC Adapter Warnings

Incorrect usage of the AC adapter could lead to fire, electric shock, overheating or damage to the AC adapter.

- The AC adapter should be plugged into a nearby, easily accessible electrical outlet.
- Do not use or place the AC adapter in hot places or places where heat can accumulate, such as:
 - places that receive direct sunlight, or near sources of heat such as stoves and heaters
 - on electric blankets or carpets with long fibres
 - on top of AV equipment
 - outdoors or in hot cars
- Do not use the AC adapter in places which have high humidity or where water might leak. Additionally, do not handle it with dirty or greasy hands.
- Do not place any items containing liquids such as vases on top of the AC adapter.
- Ensure that the AC plug is fully inserted into the electrical outlet.
- Be sure to connect the AC adapter to the correct voltage (230V-240V).
- Do not apply force to the cord, for example by twisting or coiling the cord tightly, or by placing heavy objects on the cord (particularly at the base of the cord).
- Do not step on the cord, pull on the cord, wind up the cord or perform technical modifications of the cord.
- Regularly remove any build-up of dirt such as dust from the AC plug by removing it from the electrical outlet and wiping it with a dry cloth.
- When disconnecting any plugs from the console or electrical outlet, first turn the Wii U console off. Then carefully pull by the plug itself and not by the cord.
- Do not use an AC adapter that has become wet, for example with pet urine.
- The use of these products by children should only be allowed with the full supervision of a parent or legal guardian.

AC adapter rating information is located on the bottom of the unit.

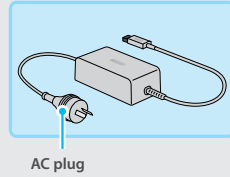

Component Names and Functions

Wii U Console

Front View (Slot cover opened)

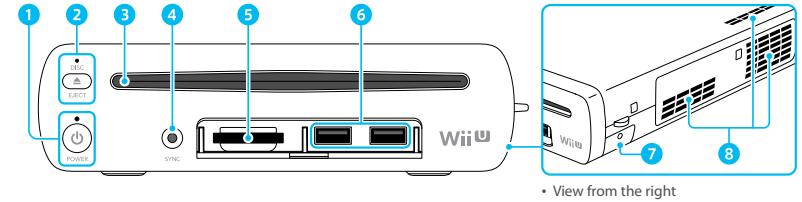

• View from the right

Rear View

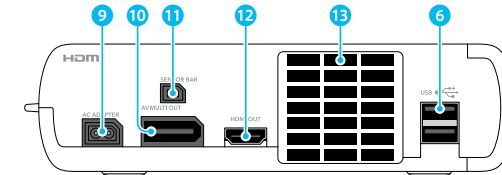

• Please note that the illustrations published in this manual may differ from the final product.

1 POWER Button

Press to turn the Wii U console on and off.

Power LED

Shows you the status of the console.

Blue: Power is on (p. 13).

Orange: Console is downloading/installing data while power is off (p. 14).

Red: Power is off (p. 14).

2 EJECT Button

Press to eject a disc.

Disc LED

Lights up white when a disc is inserted.

3 Disc slot

Used to insert Wii U discs or Wii Game Discs.

4 SYNC Button

Press to pair controllers such as the Wii U GamePad or separately-sold Wii Remote™ / Wii Remote Plus (p. 16).

5 SD Card slot

Used to insert separately-sold SD Cards (see Wii U Electronic Manual, "Using SD Cards").

6 USB ports

Used to connect separately-sold USB devices marked with (see Wii U Electronic Manual, "Using USB Devices").

7 Battery cover

Covers the compartment containing the lithium coin cell battery (CR2032).

- Do not remove this cover except when replacing the lithium coin cell battery.

8 Air intake

9 AC adapter connector

10 AV Multi Out connector

11 Sensor bar connector

12 HDMI™ port

13 Air vent

Wii U GamePad

Front View

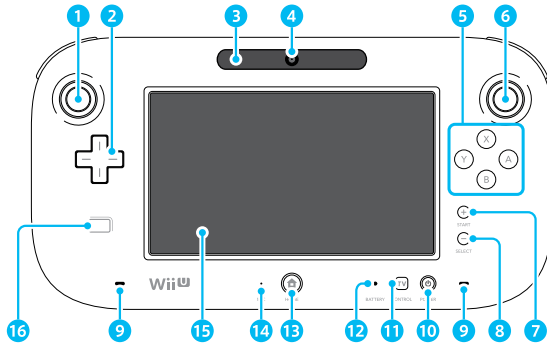

1 Left Stick (L Stick)

- The Left Stick can be pressed and used like a button.

2 + Control Pad

3 Sensor bar

- Detects movement of Wii Remotes when the Wii Remote is used to control the screen on the Wii U GamePad. (Supported software only.)
- When used in this way, this component functions in effectively the same manner as the sensor bar (RVL-014) which is included as part of the Premium Pack.
 - When using Wii Remotes to control software on the TV screen, you will need to connect a separately-sold sensor bar to the Wii U console (p. 17).

4 Camera

5 A, B, X and Y Buttons

6 Right Stick (R Stick)

- The Right Stick can be pressed and used like a button.

7 + Button

8 - Button

9 Speakers

10 POWER Button

- Press to turn the Wii U GamePad and Wii U console on and off (p. 13).



11 TV Button

- Perform TV, digital video recorder and TV tuner (e.g. cable television, satellite television) controls (p. 13).

12 Battery LED

- Lights up when charging and indicates battery level (p. 12).

13 HOME Button

- Press to configure settings for controllers such as the Wii U GamePad or Wii Remote, or to view the HOME Menu, where you can access features such as electronic manuals (see  Wii U Electronic Manual, "HOME Menu").
- You can also press the HOME Button to turn on the Wii U GamePad and Wii U console (but not to turn them off) (p. 13).
 - The HOME Button LED will light up blue when you receive a notification, when someone on your friend list comes online (see  Wii U Electronic Manual, "Friend List"), or when you receive a call via the built-in Wii U Chat software, among other events.

14 Microphone

15 Touch screen

16 NFC touchpoint

- Finds and reads data from items such as cards which support NFC (near-field communication). (Supported software only.)

Touch Screen Controls

Touch

Gently pressing the touch screen with the stylus is called "touching" (or "tapping").

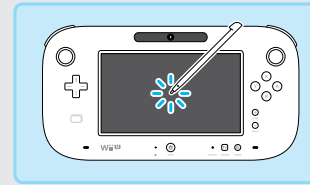

Slide

Tracing over the touch screen with the stylus held gently against it is called "sliding".

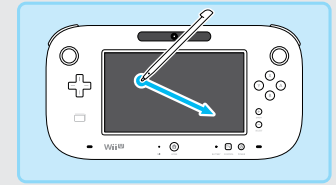

- If the touch screen does not respond properly, please refer to the "Touch screen cannot be used (no response from touch screen)" part of the Troubleshooting section (p. 41).

Standing the Wii U GamePad Up

Place the Wii U GamePad in a Wii U GamePad Stand or Wii U GamePad Cradle on a flat, stable surface (e.g. a tabletop).

- Do not place the Wii U GamePad on its side.
- Do not use the touch screen, buttons and so on when standing the Wii U GamePad up in a stand or cradle.
- The Wii U GamePad Stand and Wii U GamePad Cradle are included in the Premium Pack only.



Top View

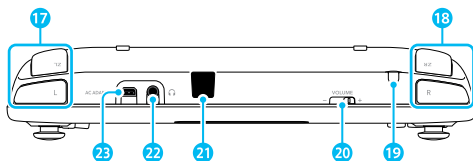

Rear View

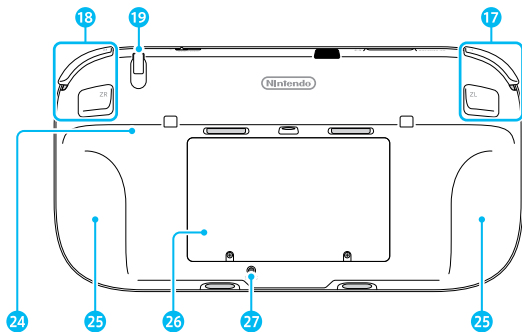

Bottom View

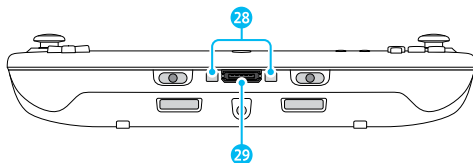

17 L Button / ZL Button

18 R Button / ZR Button

19 Stylus holder

Stores the Wii U GamePad stylus.

20 Volume control

Slide left and right to adjust the volume of the Wii U GamePad.

21 Infrared transceiver

Exchanges information using infrared communication.

22 Audio jack

Plug commercially-available headphones in here. When using headphones, ensure that you plug them in first before wearing them.

- When headphones are plugged in, the speakers will be muted.

23 AC adapter connector

Connects to the Wii U GamePad AC Adapter.

24 Support

25 Hand grips

26 Battery cover

The Wii U GamePad Battery is stored here.

- Do not remove the battery cover except when replacing the battery.

27 SYNC Button

Press to pair the Wii U GamePad with a Wii U console (p. 16).

28 Charging terminals

Connect to the charging terminals on the cradle.

29 Accessory connector

Connects to accessories for use with the Wii U GamePad.

Charging the Wii U GamePad

The battery LED will turn orange while the Wii U GamePad is charging, and will turn off when charging has finished. The battery LED may not go out if you charge the Wii U GamePad while it is in use.

- Charge only in places where the temperature is between 10 and 35°C.
- Charge the Wii U GamePad if it is being used for the first time or if it has not been used for a while.
- It may become impossible to charge the battery if you do not use the Wii U GamePad for an extended period of time. Make sure to charge the battery at least once every six months.

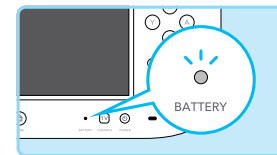

How to Charge

Connect the Wii U GamePad AC Adapter as shown in the diagrams below to charge the Wii U GamePad. Make sure to insert the plug the right way up, and ensure that the plug is firmly inserted.

Connecting the AC Adapter to the Wii U GamePad Cradle

Place the cradle on a stable surface. If you have a commercially-available cover on your Wii U GamePad, remove it before charging.

- The cradle is only included as part of the Premium Pack.

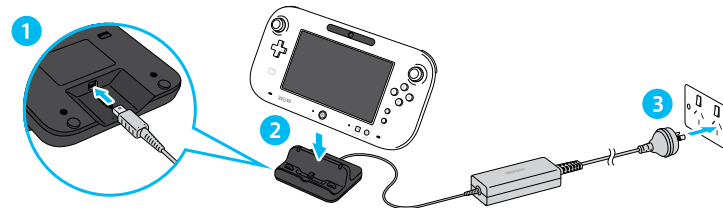

Directly Connecting the AC Adapter

Unplug the AC adapter from the electrical outlet after charging is complete, then carefully remove the plug from the Wii U GamePad, holding both the plug and the Wii U GamePad.

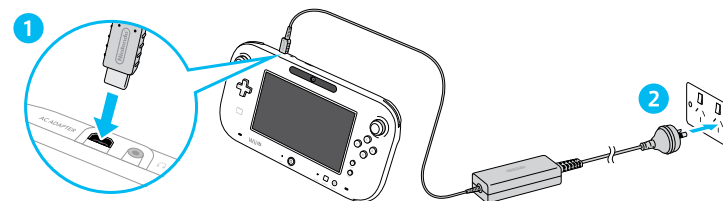

Charging Time and Battery Life

• All times are intended as a rough guide.

- **Charging time: approx. 2.5 hours**

Charging time may differ depending on factors such as usage environment and remaining battery level.

- **Battery life: approx. 3 – 5 hours**

Time may differ depending on factors such as screen brightness, features in use (e.g. camera or microphone), use of wireless communication and ambient temperature.

- The Wii U GamePad comes with the screen brightness set to 4. You can change the brightness of the screen in Controller Settings on the HOME Menu.

Power-Saving Mode

The Wii U GamePad can automatically adjust the brightness and contrast of the screen based on the images displayed in order to reduce battery consumption. To use the power-saving mode, enable it from the Wii U GamePad section of Controller Settings on the HOME Menu.

Reading the Battery LED

The behaviour of the battery LED changes depending on the remaining battery level.

- If the battery becomes depleted while playing a game, you will not be able to use the Wii U GamePad. Charge the Wii U GamePad when the battery LED turns red.

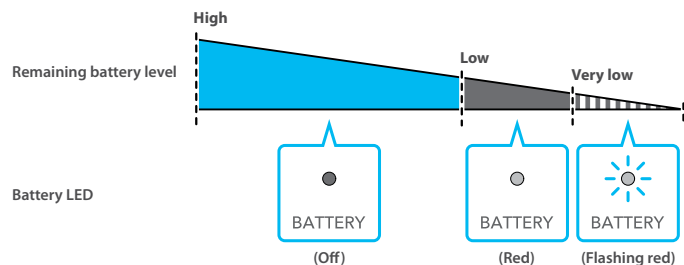

Turning the Power On / Off

You can turn the power on/off via the Wii U GamePad and other controllers, or the Wii U console.

Turning the Power On

Press (the POWER Button) or (the HOME Button) on the Wii U GamePad to turn the power on and display the Quick Start screen. The Quick Start screen will display icons for up to ten of the most recent software titles that you have used on your Wii U console, letting you start them immediately from this screen.

- To use Quick Start, you must first go to Power Settings in System Settings (p. 19) and select ENABLE in both the Standby Functions and Quick Start Settings options.
- If you have enabled standby functions, icons will also appear for software that was installed while the console was turned off.

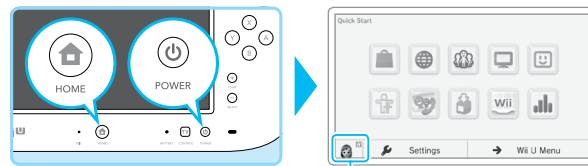

Displayed if you have set a default user for the console. Touch the Mii™ to change to another user.

Turning the Power On via the Wii U GamePad TV Button ()

Press on the Wii U GamePad to open the TV Remote screen and touch PLAY Wii U. Close the TV Remote screen to open the Quick Start screen.

- The TV Remote feature also allows you to control the TV using the Wii U GamePad, for example by turning on the TV or changing the input (see Wii U Electronic Manual, "TV Remote").

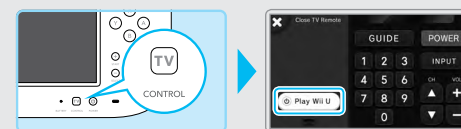

Turning the Power On Without Using the Wii U GamePad

Press **(⏻)** on the Wii U console, or on a Wii Remote or other controller, to turn on the power.

Select a user ([p. 20](#)) to display the Wii U Menu.



Turning the Wii U GamePad Screen Off

The screen of the Wii U GamePad can be turned off to reduce battery consumption if not in use. To turn off the screen, select DISPLAY OFF from under Controller Settings on the HOME Menu.

- When the screen is turned off, the battery LED will slowly turn off.

Turning the Power Off

Press and hold **(⏻)** on the Wii U GamePad for one second. When the power has been turned off, the Wii U console's power LED will turn from blue to red, and the Wii U GamePad screen will turn off.

- You can also turn the power off by holding **(⏻)** on the Wii U console or a controller such as the Wii Remote for one second.
- The power LED will remain on even if the power is turned off.
- The Wii U console cannot be turned off with the Wii U GamePad when using the Wii Menu or Wii software.

Warning: Turning the Power Back On

Do not immediately turn the power back on after turning it off. Doing so could damage the console. Once the power LED has turned red, **always wait at least four seconds** before turning the power back on.

Auto Power-Down Feature

The Auto Power-Down feature powers down the console if there has been no user interaction with the console for a certain period of time. You can reset the desired period of time before the console powers down under Auto Power-Down, accessible from Power Settings in System Settings on the Wii U Menu.

- The console comes preconfigured to automatically power down after one hour of no user interaction.

Standby Functions

This feature allows the Wii U console to automatically download and install data even after it has been turned off.

- This setting is disabled by default. (You can change it under Power Settings in System Settings on the Wii U Menu.)
- Even if this setting is enabled, data downloads and installations cannot be performed under the following circumstances:
 - If the console has been turned off by pressing the POWER Button for more than four seconds.
 - If the AC adapter is disconnected while the console is turned off.

Reading the power LED when Standby Functions are enabled

If Standby Functions are enabled and the console is turned off, the console will periodically search for available software updates, during which time the power LED will turn from red to orange. If software on the console needs updating or installing, the required data will be downloaded and installed. Once all data has been downloaded and installed, the power LED will turn back to red.

- After Standby Functions are complete, there will be a default period of one hour until the next check begins (during which the power LED will be red). You can change this period under Power Settings in System Settings on the Wii U Menu.

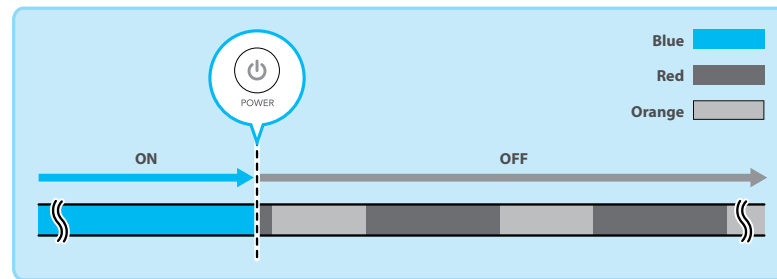

Receiving Notifications

From the Wii U Menu, you can set Quick Start to receive notifications by starting System Settings, then selecting POWER SETTINGS → QUICK START SETTINGS. When the Wii U GamePad receives a notification, a sound will alert you and the notification content will be displayed on the GamePad screen.

- The screen will turn off after a period of inactivity. To turn it off immediately touch CLOSE in the bottom left of the notifications screen.
- You can change the volume of notification alerts via SETTINGS on the Quick Start screen ([p. 13](#)).

Pairing Controllers

Controllers such as the separately-sold Wii Remote must be paired with the Wii U console before use. Once a controller has been paired, you can use the POWER Button on that controller to turn the Wii U console on and off.

- A sensor bar (p. 17) is required in order to use Wii Remotes (except for certain software titles).
- If you pair a controller with one Wii U console and then wish to use it with another console, you must pair the controller with that console first. The same applies if you wish to use a Wii-compatible controller with a Wii™ console once it is paired with the Wii U console.
- To pair a Wii Balance Board™, refer to the manual for the software that supports it.

Pairing Wii Remotes and Other Controllers

To pair controllers such as Wii Remotes, press the SYNC Button on the Wii U console (once) while the Wii U Menu is displayed. You can then pair controllers by following the instructions on the TV screen and pressing the SYNC Button on the controller.

- You can pair up to a total of ten controllers (this number does not include the Wii U GamePad). Once you exceed this limit, existing controller pairings will be deleted, starting from the oldest pairing.



Once pairing has completed, a Player LED on the controller will light up. The Player LED that lights up indicates the player number assigned to that controller.

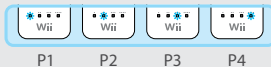

Example: Wii Remotes

Pairing a Wii U GamePad

To pair a Wii U GamePad, press the SYNC Button on the Wii U console twice while the Wii U Menu is displayed. Next, press the SYNC Button on the Wii U GamePad and pair it by entering the symbols shown on the TV screen, following the on-screen explanation.

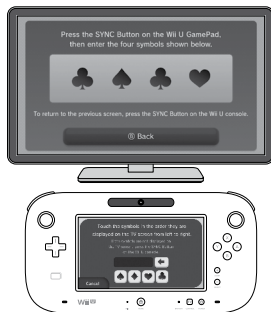

Positioning the Sensor Bar

Before using Wii Remotes, you must position a sensor bar (RVL-014) following the steps below. A sensor bar is included as part of the Premium Pack. (Please note that Wii Remotes and the sensor bar are not compatible with some software.)

How to Position the Sensor Bar

1 Connect the sensor bar to the Wii U console

Plug it into the sensor bar connector at the rear of the Wii U console. Ensure that the plug is firmly inserted. If you purchased the Basic Pack, you can use a sensor bar from a Wii console set you already own.

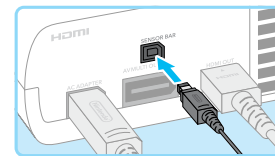

2 Remove the protective film from the bottom of the sensor bar

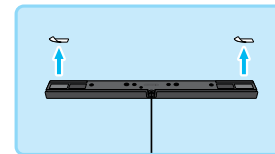

3 Place the sensor bar either above or below the television screen

Before placing the sensor bar, read the "Sensor Bar Placement Tips" section (p. 18).

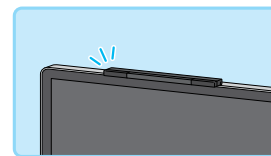

If You Place the Sensor Bar Below the TV Screen

Start System Settings from the Wii U Menu, select Wii REMOTE AND SENSOR BAR, then select SET SENSOR BAR POSITION and finally select BELOW TV to specify the position of your sensor bar.



Sensor Bar Placement Tips

- The sensor bar should be in a central position and facing straight ahead.

- Do not mount the sensor bar on the TV's ventilation.

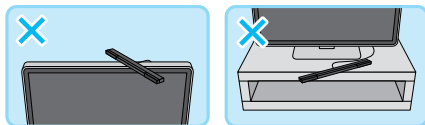
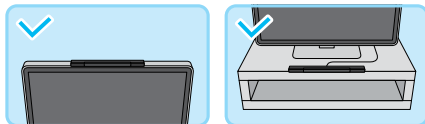

- Place the sensor bar as far forwards (so that it is slightly in front of the TV) and as level as possible.



- If placing the sensor bar on a TV stand, place it as near to the screen as possible.

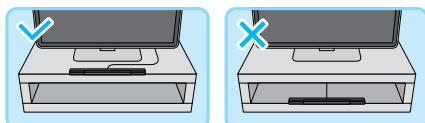

Play Environment

Use the Wii Remote in an environment that meets the following conditions:

- you should be able to see the sensor bar straight in front of you
- there should be no obstacles between the sensor bar and the Wii Remote
- you should be standing or sitting in front of the television
- you should be 1–3m away from the sensor bar

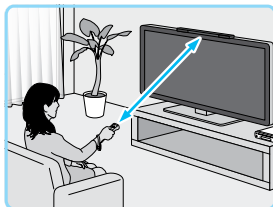

If you are having difficulty using the Wii Remote, adjust its settings by starting System Settings from the Wii U Menu and then selecting Wii REMOTE AND SENSOR BAR, or consult the "Wii Remote cannot be operated (does not respond correctly)" section of the Troubleshooting chapter (p. 42).

System Settings

In System Settings, you can configure Wii U console settings such as internet connections or data management, and view information such as the system version of the Wii U console.

- These settings are shared across all users. You cannot configure settings for individual users (p. 20).



Configuring Settings

Configure settings by touching the Wii U GamePad screen. For information about the available options and the items you can configure, see [Wii U Electronic Manual](#), "System Settings".

Setting category

Select to configure individual items.

List of available settings for each category

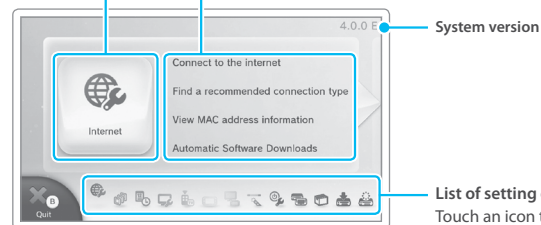

List of setting categories

Touch an icon to jump directly to the corresponding category.

Explanations of Settings

Explanations will appear on the TV screen while you are configuring settings. To scroll through the explanation on the TV screen, use the Right Stick on the Wii U GamePad.



User Settings

On the Wii U console, game save data, play time and other such items can be managed or saved for individual users. You will need to link a Nintendo Network™ ID to every user who will use online services or functions offered by Nintendo.

Access User Settings by touching the Mii in the top left of the Wii U Menu.



Nintendo Network ID

Touch LINK A NINTENDO NETWORK ID on the User Settings screen and follow the on-screen instructions.

- If you have already created a Nintendo Network ID and linked it to a Nintendo 3DS™ system, linking the same ID to your Wii U console will allow the two devices to share Nintendo eShop funds and more.
- A Nintendo Network ID is different from a Club Nintendo™ account.
- An email address is required to create a Nintendo Network ID.
- A parent or legal guardian should create a Nintendo Network ID for children. The parent or legal guardian's email address must be used.

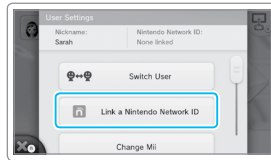

Linking a Nintendo Network ID

Linking a Nintendo Network ID to each user allows them to use services such as Miiverse™ and Nintendo eShop, and allows them to manage their friends via the friend list.

- A  will appear in the top-right corner of the user's Mii portrait after successfully linking a Nintendo Network ID.



Features available on Wii U after linking	Unlinked	Linked
View purchase history for downloadable software titles / Manage friend list	✗	✓
Access online services and functions	✗	✓
View play history / Manage save data / Manage user Mii	✓	✓

Changing User Settings

Select an option from the User Settings screen and follow the on-screen instructions.

- If you have linked the same Nintendo Network ID to both a Wii U console and a Nintendo 3DS system, changes you make to information on the ID on one device will be reflected on the other device.
- Deleting a Nintendo Network ID will delete information associated with that ID, such as your Nintendo eShop funds, which cannot then be used on other devices. For more information on deleting a Nintendo Network ID, refer to the Nintendo Network Privacy Policy.

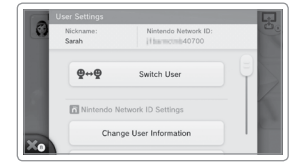

Adding / Switching Users

If the console will be used by several people, for example by members of a family, then you should first add a user for each person who will use the console. Touch SWITCH USER on the User Settings screen then follow the on-screen instructions to switch to another user or add new users.

- Up to 12 users can be added to one Wii U console.
- You can also add users from the user-selection screen after turning the Wii U console on with .

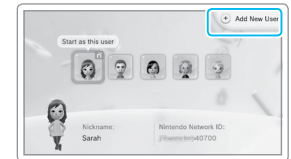
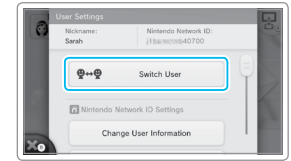

Using Wii Software

You can play Wii software (Wii Game Discs, WiiWare™, Virtual Console™ software) from the Wii Menu.

- The Wii U GamePad and Wii U Pro Controller cannot be used to play Wii software.



Preparation

You will need the following accessories (sold separately) to use the Wii Menu.

- Wii Remote (or Wii Remote Plus) (p. 16)
- Sensor bar (p. 17)

To play software, you may need a controller and accessories for each player. For more information, please refer to the manual for the software you wish to play.

Controlling the Screen

As well as the TV, you can use the Wii U GamePad screen to display the software you are using. If you are using the Wii U GamePad, then point the Wii Remote at the sensor bar on the Wii U GamePad (see Wii U Electronic Manual, “Wii Menu”).

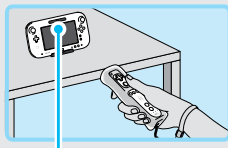

Sensor bar

Starting the Wii Menu Directly

After turning on your Wii U console with , you can open the Wii Menu directly by pressing and holding the B Button on the Wii U GamePad when the Wii U logo appears.



Turning the Wii U GamePad Screen On and Off

When viewing the Wii Menu or using Wii software, press on the Wii U GamePad to turn the screen on and off.

- In circumstances other than those described above, for example when using Wii U software, the POWER Button on the Wii U GamePad will turn the Wii U console off, so please be careful.

Transferring Software and Data from Wii to Wii U

Data saved on a Wii console, such as software and save data, can be transferred (moved) to a Wii U console.

- Data will be deleted from the Wii console once transferred.
- You cannot transfer data from a Wii U console to a Wii console. Once data has been transferred to a Wii U console, it cannot be returned to a Wii console.

You will need the following to perform a transfer:

- Wii U console pack and Wii console pack
- separately-sold SD /SDHC Memory Card (with at least 512MB of free space) (hereafter referred to as “SD Card”)
- broadband internet environment (see Quick Start Guide, “Internet Settings”)
- For more information about connecting a Wii console to the internet, refer to the Wii Operations Manual – Channels & Settings.

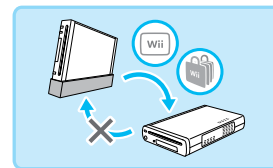

Transferable Data

The data listed below will be transferred as a set. You cannot select individual items to transfer, nor can you transfer any other kinds of data, such as save data for Nintendo GameCube™ software.

Wii Software	<ul style="list-style-type: none"> • Save data for Wii software¹ • WiiWare and save data^{1,2} • Virtual Console titles and save data^{1,2} • Add-on content for software
Wii Shop Channel	<ul style="list-style-type: none"> • Wii Points³ • Wii Shop Channel account activity
Other	<ul style="list-style-type: none"> • Mii characters⁴

¹ If the save data has been moved to an SD Card, please move it back to the Wii console before starting the transfer.

² Any software that came pre-installed on your Wii console cannot be transferred.

³ The Wii Points balance will be added to the Wii U console's Wii Shop Channel balance. You cannot perform a transfer if the total balance would exceed 10,000 Wii Points.

⁴ The Mii characters will be moved to the Mii Channel on the Wii U console's Wii Menu.

Software on the Wii console that has been deleted or moved to an SD Card

The Wii Shop Channel account activity will be moved to the Wii Shop Channel on the Wii Menu of the Wii U console. If you have deleted any software acquired through the Wii Shop Channel or moved it to an SD Card, please redownload it (free of charge) from the Wii Shop Channel on the Wii U console.

Preparing for the Transfer

Connection Check

Check the connection between the Wii U console, the Wii console and the sensor bar, and check each console's internet connectivity.

Example: A connected TV

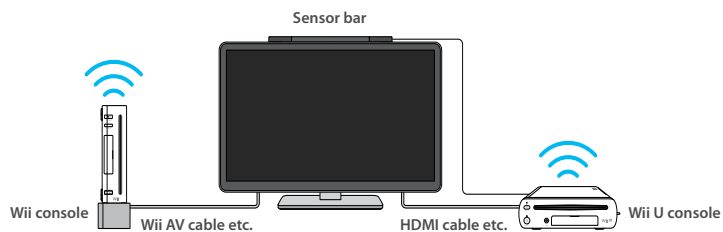

Linking a Nintendo Network ID

You must link a Nintendo Network ID (p. 20) before transferring data.



User Mii icon

Transfer Procedure

When both consoles are connected to the TV, change the TV's input to operate the Wii U and Wii in turn.

- If you are alternately connecting the Wii and Wii U consoles to the TV using one AV cable, switch the AV cable between consoles when swapping the SD Card.
- Do not remove the SD Card, turn either of the consoles off or disconnect AC adapters while data is being saved or loaded. Doing so could cause damage to the devices and/or data loss.

Wii U Console

- 1 Select the Wii Menu icon from the Wii U Menu.



- 2 Select Wii SYSTEM TRANSFER.

Wii System Transfer must be downloaded (free of charge) from the Wii Shop Channel. Its icon should appear in the Wii Menu.

- Select the system memory as the save destination.



- 3 Select the newly-appeared Wii SYSTEM TRANSFER.

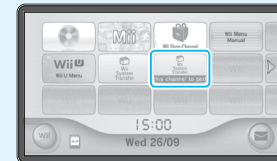

- 4 Insert the SD Card to be used for the transfer into the Wii U console.

Read the warnings on the screen and follow the on-screen guide as you perform the transfer. Information about the Wii U console will be saved to the SD Card.

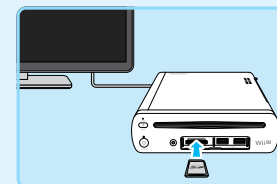

- 5 Change the TV input from the Wii U console to the Wii console.

If you only have one Wii Remote to operate both consoles, then it must be paired with the Wii console (see Wii Operations Manual – System Setup).

Wii Console

6 Download the Wii U Transfer Tool from the Wii Shop Channel on the Wii console.

Select START SHOPPING to download the Wii U Transfer Tool under Wii CHANNELS, free of charge.

- Select the Wii System Memory as the save destination.

**7** Select Wii U TRANSFER TOOL from the Wii Menu.**8** Remove the SD Card from the Wii U console and insert it into the Wii console.

Read the warnings on the screen and follow the on-screen guide as you perform the transfer. Data from the Wii console will be saved to the SD Card.

- Only data saved to the Wii System Memory will be transferred to the SD Card.

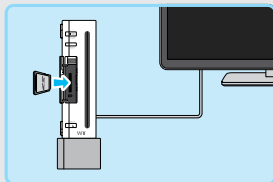
**9** Change the TV input from the Wii console to the Wii U console.

If you only have one Wii Remote to operate both consoles, then it must be paired with the Wii U console (p. 16).

Wii U Console

10 Remove the SD Card from the Wii console and insert it into the Wii U console.

Follow the on-screen instructions to transfer the Wii console data (saved to the SD Card) to the Wii U console.

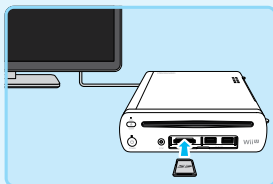

Once the transfer has completed, the data will be deleted from the SD Card.

Transferring Software and Data between Wii U Consoles

Data saved on a Wii U console, such as software and save data, can be transferred (moved) to another Wii U console.

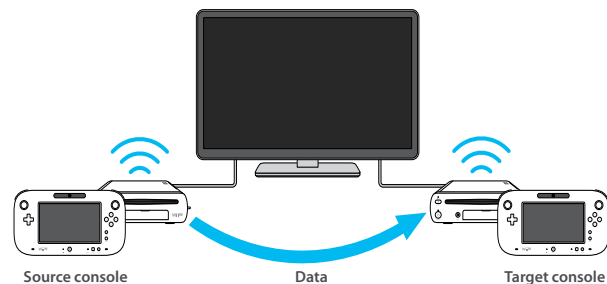

You will need the following to perform a transfer:

- source Wii U console pack and target Wii U console pack¹
- separately-sold SD/SDHC Memory Card (hereafter referred to as "SD Card")²
- broadband internet environment (see Quick Start Guide, "Internet Settings")
- a Wii Remote (or Wii Remote Plus)³

¹ If it's not possible to connect two Wii U consoles to the television set at the same time, please connect the target Wii U console to the TV.

² The amount of free space required on the SD Card will vary depending on the amount of data saved on the source console. The amount of data to be transferred will be shown on the GamePad before you insert the SD Card. (Maximum 32 GB.)

³ This is required in case you have any data related to Wii software saved to the console.

Transferring Data from a Premium Pack console to a Basic Pack console

The amount of data that can be saved on the Basic Pack console is smaller than that on the Premium Pack console. If the amount of data that needs to be copied over to the target console is larger than the available memory, you will need to use a separately-sold USB storage device. See the Nintendo website (www.support.nintendo.com) for more information.

- To check whether your Wii U console is part of a Premium Pack or Basic Pack, please check the label on the bottom of the Wii U console or the packaging it came in.
- The amount of memory available for the console in each pack is as follows:
Premium Pack: 32 GB
Basic Pack: 8 GB

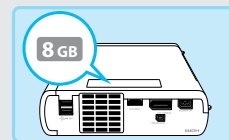

Label on bottom of console

Transferable Data

The data listed below will be transferred as a set. You cannot select individual users or items of data to transfer, nor can you transfer any settings related to controllers (pairing data or controller configurations in System Settings).

Wii U software¹	<ul style="list-style-type: none"> ● Save data for Wii U software ● Built-in software and its save data² ● Software downloaded from Nintendo eShop and its save data^{1,2} ● Software updates, add-on content for software and any passes or licences
User data	<ul style="list-style-type: none"> ● Settings for each user including Nintendo Network ID and email address ● Parental Controls settings ● Nintendo eShop account activity and funds
Wii data	<ul style="list-style-type: none"> ● Data related to Wii software and the Wii Shop Channel³
Other⁴	<ul style="list-style-type: none"> ● Mii characters

¹ Some software may not be usable on the target Wii U console.

² Mii Maker, Friend List and Miiverse can continue to be used as normal on the target console.

³ For details on which data is transferred and other precautions, please see "Transferring Software and Data from Wii to Wii U" (p. 23).

⁴ Some other system settings, such as TV display settings can continue to be used as normal on the target console.

Transfer Precautions

- Data will be deleted from the source Wii U console once transferred.
- All data (including save data and user data) on the target Wii U console will be deleted and replaced with the data from the source Wii U console.
- Any downloadable software which came pre-installed on the source Wii U console at time of purchase will only be usable on the target console.
 - If this is the case, Nintendo eShop purchase records for the software will be transferred to the Nintendo Network ID of the user selected at the time of transfer.
- Any USB storage devices in use with the target Wii U console will become unusable on both the target and source consoles. Furthermore, any data (including save data) on the USB storage devices will become unusable.
 - You will need to reformat a USB storage device to be able to use it again.
- Any downloadable software and add-on content on the target Wii U console will be deleted, but after the transfer has been completed, once you relink your Nintendo Network ID to a user on the target console, you will be able to redownload this content from Nintendo eShop at no extra charge.
- If you wish to relink a Nintendo Network ID you use on the target Wii U console, you will need the Nintendo Network ID, email address and password. Please make note of these before starting the transfer.
- If you've forgotten your Nintendo Network ID, go to the User Settings screen to check it (p. 20).
- If you've forgotten your password, touch I FORGOT on the password entry screen and follow the on-screen instructions.

Preparing for the Transfer

Connection Check

Check that both Wii U consoles are able to connect to the internet via the same access point.

Check the Nintendo Network ID

You must have a Nintendo Network ID (p. 20) linked to the source console before transferring data.

- There is no need to link the Nintendo Network ID on the target console.



User Mii icon

Transfer Procedure

Control each console using the respective Wii U GamePad.

- Do not remove the SD Card, turn either of the consoles off or disconnect AC adapters while data is being saved or loaded. Doing so could cause damage to the devices and/or data loss.

1 **Source console** **Target console**
From the Wii U Menu, open System Settings and touch SOFTWARE/DATA TRANSFER.

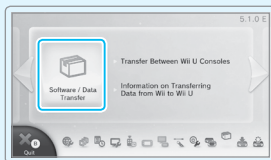

2 **Source console** **Target console**
Select TRANSFER BETWEEN Wii U CONSOLES.

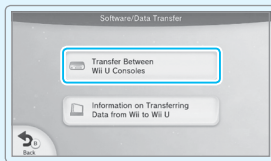

Please read and follow the on-screen instructions carefully. The required space needed on the SD Card will be shown after step **3**.

3 **Source console** **Target console**
Specify which console should be the source and which the target.

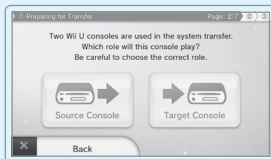

Touch the relevant option on each GamePad and follow the on-screen instructions.

4 Insert the SD Card into the source Wii U console.

The data from the source console will be copied to the SD Card.

- Downloadable software and data on the source Wii U console will not be copied to the SD Card. After the transfer is completed, it will be redownloaded automatically from Nintendo eShop at no extra charge (see below).

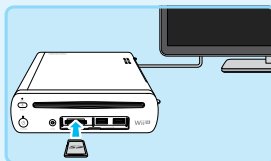

5 Remove the SD Card from the source Wii U console and insert it into the target Wii U console.

The data on the SD Card (the data from the source Wii U console) will be copied to the target Wii U console.

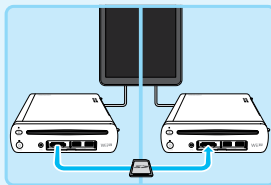

Once the data has finished being copied to the target Wii U console, the transfer is complete, and you can now use the console as normal.

You can use any USB storage devices that you used with the source console as normal with the target Wii U console.

- Data saved to the SD Card during the transfer process will be deleted once the transfer is complete.
- Controllers that you used on the source console will need to be paired to the target console before they can be used (p. 16).

Automatic downloads of software and data on the source console

After the transfer has been completed, you can check the progress of automatic downloads under Download Management in the Wii U Menu (see ? Wii U Electronic Manual).

- If more than 64 items need to be downloaded, the additional items will need to be downloaded individually from Nintendo eShop. Please check this in Download Management.
- You must wait for a software download to finish before you can play it.
- Downloading all items may take some time.

Calibrating Controllers

If the touch screen of the Wii U GamePad does not respond correctly, or if the control sticks of controllers in general do not respond correctly, follow the instructions here in order to perform calibration.

Calibrating the Touch Screen

Calibrate the touch screen using the Wii U GamePad option in System Settings on the Wii U Menu. If you are unable to operate the Wii U Menu using touch controls, you can use the **+** Control Pad and the A Button instead.

Calibrating the Control Sticks

The Left Stick and Right Stick of the Wii U GamePad are analogue control sticks. The angle and direction of these control sticks are read by the controllers to allow you to perform precision controls. When the control sticks are not tilted in any direction, their status is referred to as the "neutral position".

If the control sticks are tilted in any direction when performing the operations listed below, they will be misrecognised as being in the neutral position, causing them to function incorrectly:

- Turning the power to the console on
- Starting software
- Closing software and returning to the Wii U Menu

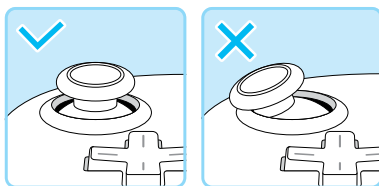

Example: Wii U GamePad Left Stick

■ Calibration (Resetting the Neutral Position)

To reset the neutral position, stop touching the control sticks, then press and hold the A, B, + and - Buttons for at least three seconds.

Calibrating the Motion Controls

If the screen moves during play even though you are not operating the Wii U GamePad, or the movement of the screen does not match the movement of the Wii U GamePad correctly, then go to the HOME Menu and hold the Y Button and the B Button for at least three seconds. When the calibration screen is displayed, place the Wii U GamePad on a flat surface, and select CALIBRATE or REVERT TO DEFAULTS.

- After selecting CALIBRATE, please make sure the Wii U GamePad is placed on a flat surface.

Replacing and Removing Batteries

You should replace the Wii U GamePad Battery if the controller can only be used for extremely short periods of time.

Additionally, you should replace or remove the lithium coin cell battery in the console itself if the internal clock does not function correctly or if you intend to dispose of the console.

- **The replacement or removal of batteries should only be carried out by an adult.**
- If the AC adapter is connected to the Wii U GamePad, ensure that you disconnect it as well.
- The capacity of the battery in the Wii U GamePad will gradually decrease over time with repeated recharging. After 500 charges, the battery capacity will be at 70%.

Wii U GamePad Battery

The Wii U GamePad Battery (WUP-012) is not available from retail outlets. If you require a replacement, please contact Nintendo Customer Service (see Important Information booklet).

- Please contact Nintendo Customer Service to purchase the Wii U GamePad High-Capacity Battery (2550mAh) (WUP-013).

1 Turn the power off

If the power LED on the Wii U console is blue, hold on the Wii U GamePad for one second to turn both the Wii U console and Wii U GamePad off.

2 Loosen the battery cover screws

There are two screws. They are designed not to fall out from the battery cover once loosened.

- To avoid damaging the heads of the screws, use a size 0 cross-head screwdriver.

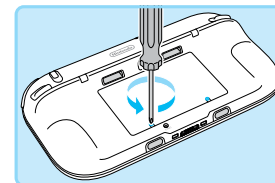

3 Remove the battery cover

Lift up the edge of the battery cover, then pull it out.

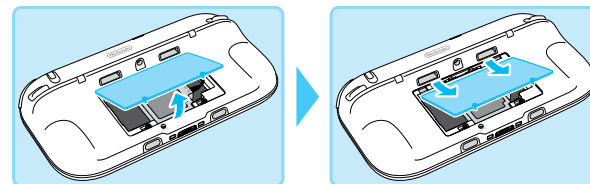

4 Remove the old battery

Unplug the battery from the terminal by placing your fingers on the part of the connector plug marked ▼ as shown in the diagrams below.

- Never disconnect the battery from the terminal by pulling on the cable, and never use anything other than your fingers to touch the part marked ▼, such as a screwdriver.
- After removing the battery, do not touch the terminals with metallic objects to avoid shorting (p. 35).

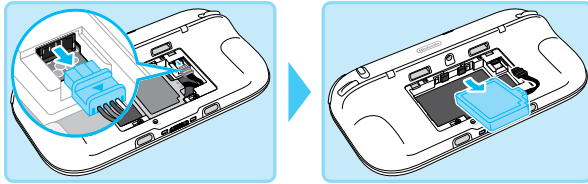

5 Wait for at least ten seconds, then install the new battery

Make sure the battery is the right way up, then install it as shown in the diagrams below.

- If you insert the new battery without waiting, the battery LED may stop lighting up or flashing.

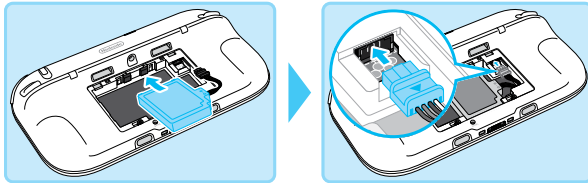

6 Replace the battery cover

Put the battery cover back into position and tighten the two screws.

- Always replace the battery cover. If the battery cover is not put back into position, any shock to the battery may cause damage to the battery, fire or rupture of the battery.
- To avoid damaging the heads of the screws, use a size 0 cross-head screwdriver.

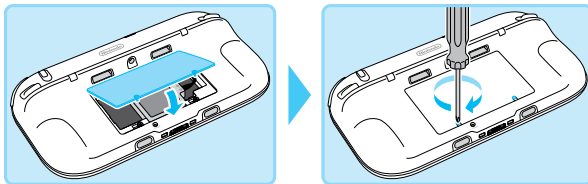

7 Charge the GamePad

Make sure to charge the GamePad after replacing the battery (p. 11).

8 Turn the power on

Press  to turn on the GamePad.

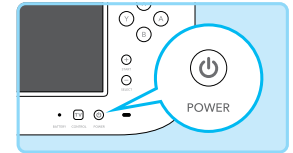

Handling Used Batteries

- Insulate the battery using tape to prevent shorting by metallic objects.
- Do not disassemble the battery.

The Wii U GamePad uses a lithium-ion rechargeable battery. Please dispose of this product in accordance with local regulations.

- Discarding batteries in your general household waste can be harmful to the environment. When disposing of the battery, follow appropriate local guidelines and regulations.

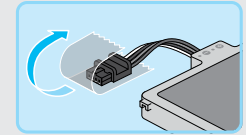

Wii U GamePad Battery

Wii U Console Battery

1 Ensure that the disc LED is not lit

If the disc LED is lit, press the EJECT Button and remove the disc.

2 Turn off the console and disconnect the AC adapter

Ensure that the power LED is red, then unplug the Wii U AC Adapter from the electrical outlet.

3 Turn over the console and remove the battery cover

The battery cover screw is designed not to fall out once loosened.

- To avoid damaging the head of the screw, use a size 0 cross-head screwdriver.

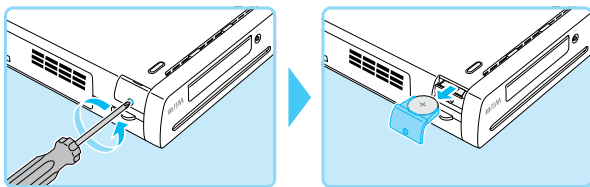

4 Remove the battery, install the new battery and replace the battery cover

After removing the battery, place the new lithium coin cell battery (CR2032) with the positive (+) side facing up, then replace the battery cover.

- To avoid damaging the head of the screw, use a size 0 cross-head screwdriver.

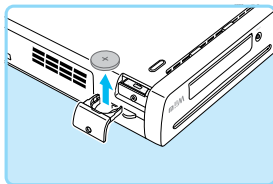

Handling Used Lithium Coin Cell Batteries

- Insulate the positive (+) and negative (-) sides using tape to prevent shorting by metallic objects.
- Do not disassemble the battery.
- Discarding batteries in your general household waste can be harmful to the environment. When disposing of the battery, follow appropriate local guidelines and regulations.

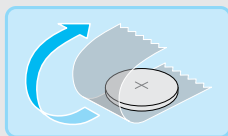

Troubleshooting

This manual covers the topics listed below. Please review the troubleshooting information carefully before contacting Nintendo Customer Service (see Important Information booklet).

- Power and Temperature of Devices ([below](#))
- GamePad Charging and Batteries ([p. 39](#))
- TV Display and Audio ([p. 40](#))
- Wii U GamePad Display and Touch Screen Response ([p. 41](#))
- Controller Operations ([p. 42](#))

- For information on other topics, see the Troubleshooting chapter of the Wii U Electronic Manual on the Wii U GamePad.
- For information on the Wii Menu, see the Wii Menu Electronic Manual.
- Also refer to any documentation for individual software titles or accessories.

Power and Temperature of Devices

Wii U console does not turn on

Is the AC or DC plug of the AC adapter inserted firmly?	Ensure that the plugs are firmly inserted (see Quick Start Guide).
Is the power LED of the Wii U console lit?	<p>If the power LED does not light up after pressing the POWER Button on the Wii U console, unplug the AC adapter from the electrical outlet, wait two minutes, then plug it back in to the electrical outlet.</p> <ul style="list-style-type: none"> If the power LED is flashing red Unplug the AC adapter from the electrical outlet, ensure that it is not placed somewhere that accumulates heat (e.g. on top of AV equipment) and that there is at least 10cm of well-ventilated space around the air intake and air vents. Wait for two minutes, then plug the AC adapter back in to the electrical outlet and turn the power on. If the power LED is flashing blue Please contact Nintendo Customer Service (see Important Information booklet).

Wii U GamePad does not turn on

Is the battery depleted?	Charge the Wii U GamePad (p. 11).
Is the battery correctly inserted?	If the battery LED flashes orange during charging, or if the problem continues even though the Wii U GamePad is already charged, take the Wii U GamePad Battery out for at least ten seconds. Once replaced, check to see if it is charged (p. 33).

Wii U console suddenly turns off

Has dust collected around the air intake or air vents?	Unplug the AC adapter from the electrical outlet and use a vacuum cleaner or similar to remove the dust from the air intake or air vents.
Has the console been placed somewhere heat can accumulate or on top of AV equipment?	Place the console somewhere else, or create at least 10cm of well-ventilated space around the air intake and air vents.
Is the Auto Power-Down feature enabled?	If the Auto Power-Down feature has been enabled, the console will power down automatically if there has been no user interaction for a certain period of time. This period of time can be reconfigured under Power Settings in System Settings on the Wii U Menu.
Are you using any unsupported USB devices with your Wii U console?	If you are using USB devices that are incompatible with the Wii U console, there is a chance that the console will switch itself off without warning. Disconnect the USB device and only use USB devices that have been verified as compatible by Nintendo. See the Nintendo website (www.support.nintendo.com) for more information.

Wii U console does not turn off (power LED does not turn red)

Are you holding down the POWER Button for one second?	If the Wii U console does not turn off after holding the POWER Button for one second (the power LED does not turn red), hold the POWER Button on the Wii U console for at least four seconds. Please note that the power LED does not go off even when the power is off. <ul style="list-style-type: none"> The Wii U console cannot be turned off with the Wii U GamePad when using the Wii Menu or Wii Software.
Are you pressing the HOME Button on the Wii U GamePad?	The HOME Button on the GamePad does not turn the Wii U console off. To turn the power off, press the POWER Button on either the Wii U console or GamePad.
Are Standby Functions enabled?	If Standby Functions are enabled (p. 14), when the console is powered down the power LED will turn from red to orange. Once any outstanding downloads or installations are complete, the power LED will automatically turn back to red.

Wii U GamePad does not turn off

Are you holding down the POWER Button on the Wii U GamePad for one second?	If the Wii U GamePad does not turn off after holding its POWER Button down for one second, try holding it down for approximately four seconds.
--	--

Wii U GamePad Battery LED does not light up when turning the controller on

The battery LED lights up when charging or if the battery level is low.

Wii U console or controller gets hot

Are you using it in somewhere with a high ambient temperature, or using the controller while it is charging?	Using the console or controllers under such conditions will cause them to become warmer. The operable environments (room temperatures) for the console and controllers are as follows: Wii U console: 10–40°C Wii U GamePad: 10–35°C • Please be careful, as contact with the hotter parts of the controller for long periods of time may cause skin burns, even if the controller does not feel particularly hot to touch.
--	--

GamePad Charging and Batteries

Cannot charge / charging takes a long time

Are you using a supported device?	Use the Wii U GamePad AC Adapter (WUP-011(AUS)).
Is the AC adapter firmly plugged in?	Unplug the AC adapter from the mains, wait at least 20 seconds, then charge the controller by plugging the AC adapter firmly into the AC adapter connector or cradle and the electrical outlet (p. 11).
Is there a cover on the Wii U GamePad?	If you are using a commercially-available cover, the Wii U GamePad cannot be charged. Remove the cover before charging.
Are you charging the device in an environment of 10–35°C?	Charge the device in an environment of 10–35°C. The battery will not charge normally in warmer or cooler environments.
Is the battery LED flashing orange?	Ensure that the battery is correctly installed (p. 33). If the battery LED is still flashing orange, contact Nintendo Customer Service (see  Important Information booklet).

Lithium-ion batteries can slowly lose their charge over time if they have not been used for a while. If the Wii U GamePad is not used for an extended period of time, the battery may become overdischarged and may be impossible to charge when connecting the AC adapter. Make sure to charge the battery at least once every six months.

Cannot use software for long periods of time even on a full charge / charging takes a long time

Are you using the software or charging the device in an environment under 10°C?	During use in environments cooler than 10°C, prolonged use may not be possible, and it may take longer than usual to charge the device.
Has the battery reached the end of its life?	The battery life will decrease with repeated charging. If the duration of time the battery can be used becomes extremely low, the battery has reached the end of its life. Please replace it with a new battery (p. 33).

The battery has expanded

Lithium-ion batteries are subject to degradation over time and can expand through repeated recharging. This is not a malfunction or a potential safety hazard. Please replace the battery if its expansion is affecting battery life ([p. 33](#)).
If the battery leaks, do not touch it and contact Nintendo Customer Service (see  Important Information booklet).

TV Display and Audio

No picture on TV / no audio from TV	
Is the cable connecting the console to the TV correctly inserted?	Unplug the cable, then reinsert it firmly, making sure the connectors are pushed all the way in.
Have you changed your cable or TV?	If you are using a different cable or TV than usual, use the Wii U GamePad and go to the TV option in System Settings on the Wii U Menu and configure the correct settings for the TV and the cable you are using.
Is the cable plugged into the correct place, and is the TV set to the correct input?	Make sure the TV is set to receive input from the correct source and the cable is plugged into the right port. <ul style="list-style-type: none"> Depending on your TV, it may take ten seconds or more before the picture appears after changing the input.
If you are not using an audio amplifier or other audio equipment, are your output cable settings set to NON-HDMI?	Go to Configure TV Sound under the TV option in System Settings on the Wii U Menu, and change the Output Cable Settings to HDMI.
Have you disassembled or modified the console, or connected any accessories etc. not authorised by Nintendo?	Remove or disconnect any parts / accessories installed in or connected to the console.

The sound partially cuts out	
Have you connected an audio amplifier to your Wii U console?	If you are using an audio amplifier, please make sure it supports surround sound. For more information, please see Wii U Electronic Manual , "Connecting to Audio Equipment".
Is the sound set to Surround, even though no audio amplifier is connected?	<ul style="list-style-type: none"> If you are not using an audio amplifier, change the setting from SURROUND to STEREO (or MONO) under the TV option in System Settings on the Wii U Menu.

I want to use a third party audio amplifier or active speakers
Please refer to the Wii U Electronic Manual , "Connecting to Audio Equipment", or the instruction booklet for the audio equipment, for more information.

Display doesn't match screen size
If the display expands beyond the edges of the TV screen, you can adjust it in Screen Size under the TV option in System Settings. <ul style="list-style-type: none"> Depending on the type of TV you are using, the display may appear smaller than the screen. This can be adjusted in your TV's screen size settings.

Wii U GamePad Display and Touch Screen Response

Wii U GamePad screen does not turn on	
Is the Wii U GamePad Battery LED glowing blue?	If the battery LED is glowing blue, then the display has been turned off. Press any of the buttons (except for the POWER Button) to turn the display back on.
Does the screen turn on several seconds after connecting the Wii U GamePad AC Adapter and pressing the POWER Button?	If the screen turns on after doing so, then the battery is depleted. Leave the AC adapter connected to charge the battery. If the screen does not turn on, contact Nintendo Customer Service (see Important Information booklet).

Wii U GamePad makes a sound / GamePad screen suddenly turns on, even though the console is turned off
If you have set Quick Start to receive notifications (by starting System Settings in the Wii U Menu and selecting POWER SETTINGS → QUICK START SETTINGS), the GamePad will alert you to new notifications by displaying them on its screen and making a sound. <ul style="list-style-type: none"> The screen will turn off by itself after a short while. To turn it off immediately touch CLOSE in the bottom left of the notifications screen. You can configure the alert volume in the Quick Start settings (p. 13).

Touch screen cannot be used (no response from touch screen)	
Are there any obstacles that could cause wireless interference between the Wii U console and the Wii U GamePad?	Do not use any items such as metallic TV stands or shelves, or devices that could cause interference such as AV equipment, microwaves or cordless phones, near the Wii U console and Wii U GamePad.
Is the touch screen response inaccurate?	If the touch screen response is inaccurate, recalibrate it using the Wii U GamePad option in System Settings on the Wii U Menu. If this problem prevents you from operating the Wii U Menu using touch controls, you can use the Control Pad and the A Button to control the menu instead.
Have you attached a commercially-available protective sheet to the touch screen?	<p>In the following circumstances, the touch screen may not function correctly. Please refer to the documentation supplied with the protective sheet, and reattach it correctly.</p> <ul style="list-style-type: none"> Air or dirt has become trapped between the protective sheet and touch screen The protective sheet is misaligned <ul style="list-style-type: none"> If the protective sheet is misaligned, please reattach the sheet without pushing the edges under the Wii U GamePad frame. The protective sheet has slid between the frame and the touch screen <p>The Wii U GamePad is operating correctly if you remove the protective sheet and touch screen controls work as normal.</p>



Wii U GamePad picture is distorted (blocky) / sound cuts out	
Are there any obstacles that could cause wireless interference between the Wii U console and the Wii U GamePad?	Do not use any items such as metallic TV stands or shelves, or devices that could cause interference such as AV equipment, microwaves or cordless phones, near the Wii U console and Wii U GamePad.
Due to the way wireless communication works you may experience interruptions in sound or video during use. This is not indicative of a fault.	

Wii U GamePad screen hue changes suddenly / brightness changes and it becomes difficult to see bright colours	
Has power-saving mode been enabled?	When enabled, the power-saving mode will automatically adjust the screen brightness and colour gradient depending on the picture displayed in order to reduce battery consumption. This can lead to pale colours whitening and other colours changing. To maintain fixed colours and brightness levels, disable the power-saving mode from the HOME Menu (p. 12).

Black or bright points on the Wii U GamePad screen that do not go away
Small numbers of stuck or dead pixels and occasional uneven brightness are a characteristic of LCD screens. These are normal and should not be considered as a defect.

Controller Operations

The cursor or character moves on its own	
Have the controls slipped out of neutral position?	For the Wii U GamePad please see page 32. For other controllers, please refer refer to their respective manuals.

Wii Remote cannot be operated (does not respond correctly)	
Is the Player LED for the Wii Remote lit?	Press any button on the Wii Remote (except for the POWER Button). If no Player LEDs light up, check that the batteries are inserted correctly. If the Player LEDs still do not light up, replace both batteries in the Wii Remote.
Has the Wii Remote been paired with the Wii U console you are using?	Press the SYNC Button on the Wii U console and pair the Wii Remote following the on-screen instructions.
Is the sensor bar too close or too far away?	Use the Wii Remote at a distance of one to three metres from the sensor bar (30cm – 1m if pointing the Wii Remote at the Wii U GamePad). If the response is still erratic, adjust the sensitivity of the Wii Remote using the Adjust Wii Remote Pointer Sensitivity option in System Settings on the Wii U Menu.
Are there obstacles in front of the sensor bar?	Remove any obstacles between the Wii Remote and sensor bar.

Has the sensor bar connected to the Wii U console been positioned correctly?	Ensure that the sensor bar has been positioned correctly (p. 17). If this does not fix the problem, make sure that the sensor bar plug has been inserted firmly.
Are there any bright sources of light coming from near the sensor bar, such as windows without curtains, bright light bulbs, and so on?	<p>Check for the following possible causes:</p> <ul style="list-style-type: none"> ● Bright sunlight coming through windows If there is a window uncovered by curtains or blinds near the sensor bar, the Wii Remote will not function correctly. Close the curtains or pull down the blinds. ● Sensor bar is being reflected on a highly reflective surface The Wii Remote may not function correctly if it detects a reflection of the sensor bar coming from a reflective surface such as a tabletop. Place a tablecloth or other covering on the reflective surface to prevent the sensor bar from being reflected. ● Visible light sources near the sensor bar If there are any light sources (such as electric lights) near the sensor bar that are visible from where you are using the Wii Remote, these may prevent the Wii Remote from functioning correctly. Turn off those lights if this is the case. ● Sources of infrared light near the TV Move or stop using any items that emit light or heat that are near the sensor bar, such as electric, propane or kerosene heaters, candles or fireplaces, or stoves.
Is the Wii Remote pointing towards the sensor bar?	Point the Wii Remote at the sensor bar when using it.
<p>If the Wii Remote does not function correctly after checking all of the above, press the POWER Button on the Wii U console for at least four seconds, then unplug the Wii U AC Adapter from the electrical outlet once the power LED has turned red. Wait for approximately two minutes, then plug the AC adapter back in and turn the Wii U console on.</p> <ul style="list-style-type: none"> • If the power LED doesn't turn red even after pressing the POWER Button for at least four seconds, unplug the AC adapter from the electrical outlet. 	